

4. Complete the Trains

• MAKE A TRAIN OF A GIVEN NUMBER

STUDENT NEEDS:
worksheets

 25 minutes

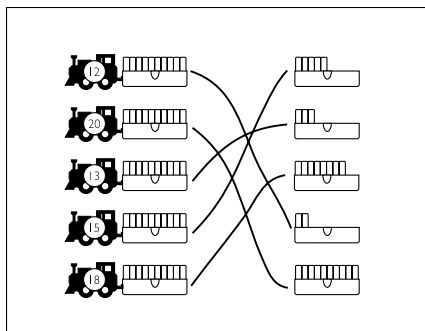
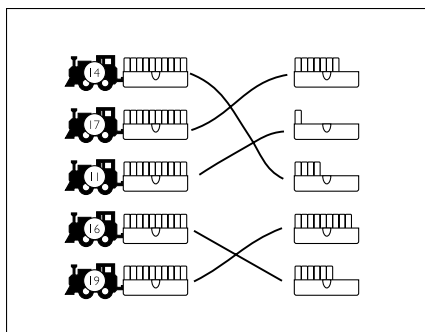

GROUP ACTIVITY:

1. Write the number 15 on the board.
2. Show the class one full holder and an empty holder.
3. Ask a volunteer to add the correct number of blocks (5) to make a train of 15.
4. Pointing to the blocks one at a time, count the 15 blocks by ones.
5. Emphasize that a train of 15 blocks has one full car and five leftover blocks in the last car. Emphasize that the digits (1 5) tell you what the train will look like (1 full car, 5 leftover or 1 ten, 5 ones).
6. Repeat the above steps with the numbers 12 and 19.
7. Explain the worksheet.
8. *Optional:* Point out that each number has a “1” in the ten’s place and that each train will start with one full car of ten blocks.

INDEPENDENT WORK:

1. Students read the number written on the engine.
2. Students draw a line from that (incomplete) train to the holder of blocks that would complete the train correctly.
3. Repeat for all trains.

Assessment:

DOES THE STUDENT:

- connect the cars to make the correct train for the number
- recognize that the first digit in each number represents the number of full cars and that the second digit represents the number of leftover blocks in the cars

Differentiation:

REINFORCEMENT:

- Provide students with the blocks and have small groups construct the train for each number.
- Students count the blocks in each holder in the right-hand column and write the number next to it, then draw lines to match the correct holders.
- Instead of drawing lines between the two columns of holders, have students cut out the holders in the right column on each worksheet, then glue them to make the correct trains from the first column.

EXTENSION:

- Before photocopying, eliminate the right-hand column from the worksheets. Ask students to draw a holder containing the correct number of blocks behind each full car to make the number shown on the engine.

Name: _____

For each number, draw a line to complete the train correctly.

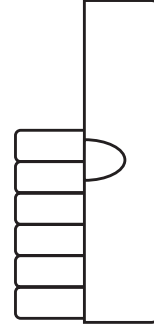
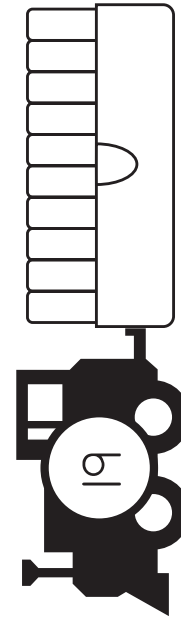
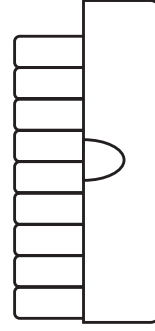
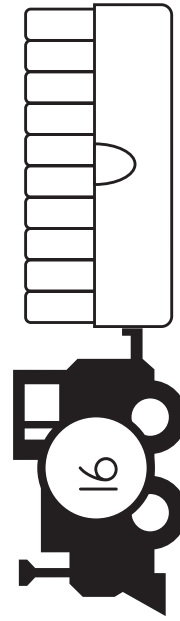
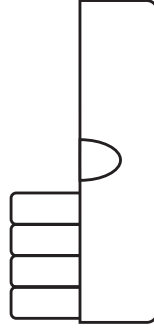
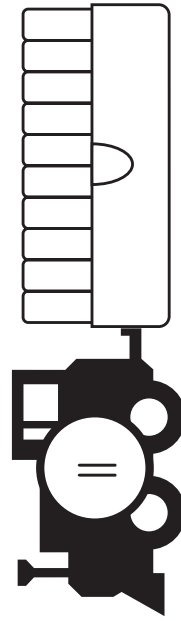
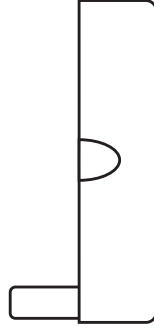
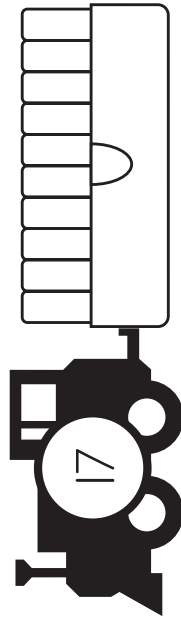
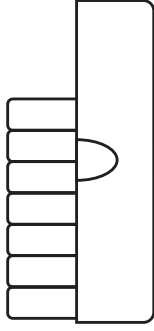
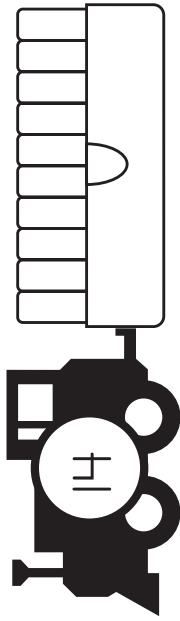

Name: _____

For each number, draw a line to complete the train correctly.

